

... Cutting tubes manually

# MRA

## Metal Tube Cutter

The clever solution for cutting tubes manually.

This Metal Tube Cutter is especially designed for cramped working places and for chipless cutting processes. For manual cutting of metal tubes in each position. Easy to use – first-rate cutting technology.

### Advantages:

- No electricity required
- Chipless cutting procedure
- Requires little space
- For badly accessible areas

The patented cutting technique used in designing the MRA is based on the diameter-specific clamping shells and the flexible multi-roller cutting chain. Both these components are made of hardened, wear resistant steel and provide the following advantages:

- Long service life of the components
- The cutting chain is at a right-angle around the tube
- The MRA runs on track rollers on the clamping shells
- Minimum hand movements
- Tubes made of stainless steel can be cut

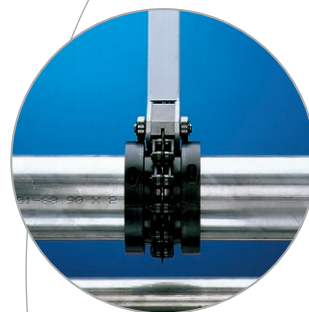
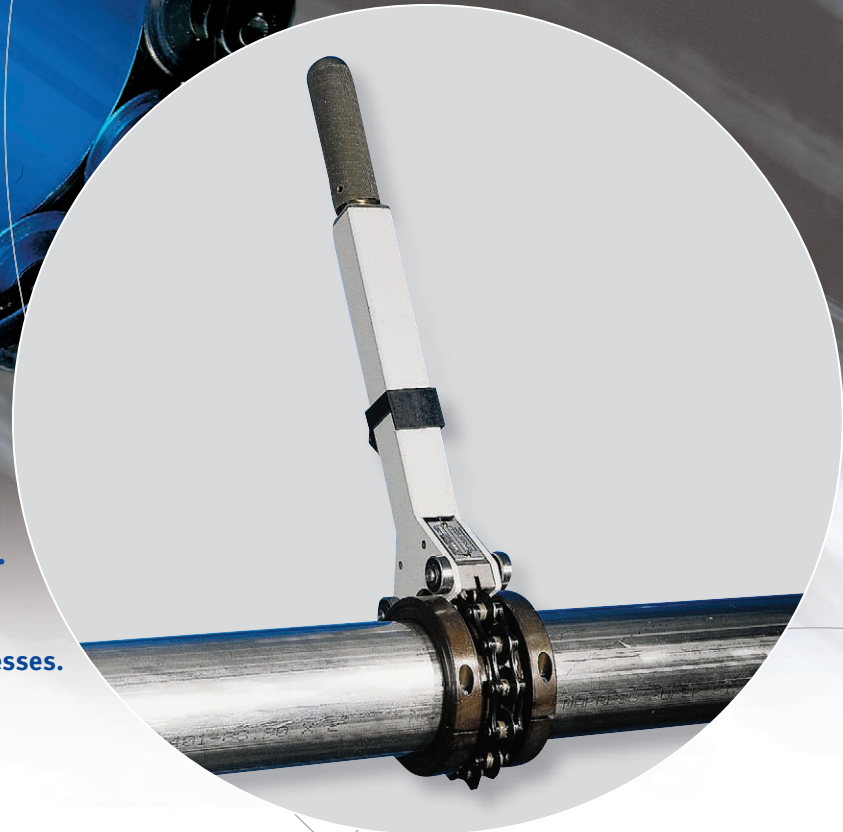

... Guiding of the multi-roller cutting chain and the MRA through the clamping shells



Diameter-specific clamping jaws.



Sturdy, plastic carrying case (ABS).

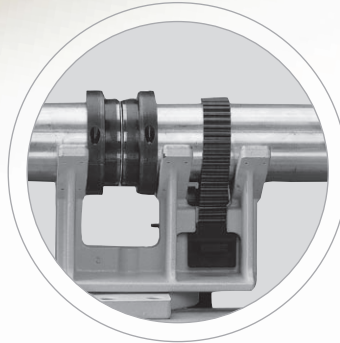

Pipe vice for pipes up to OD 300 mm (11.81 inch). Reversible vice with plastic clamping strape and an integrated clamping shell bearing.  
**Code 790 008 008**

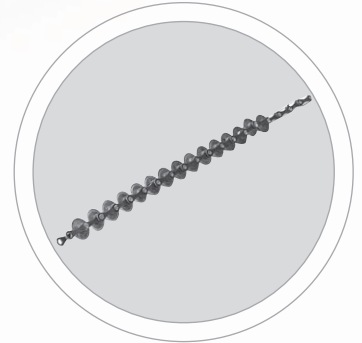

Multi-roller cutting chains: The cutting wheels are made from hardened steel.

## Metal Tube Cutter MRA

### Technical data

Dimensions	450 x 105 mm (17.7 x 4.1 inch)	
Weight MRA (without chain)	3.1 kg	
Weight complete (with case)	8.0 kg	
Versions	MRA Standard MRA HP*	<b>Code 790 008 001</b> <b>Code 790 008 002</b>
Scope of delivery	1 Metal Tube Cutter MRA, tools, 1 tube of lubricating compound GF TOP, 1 pair of working gloves, 1 plastic carrying case (ABS)	

### Working range

Tube outer diameter OD	33.7 – 254.0 mm (1.327 – 10.000 inch)	
Wall thickness (depends on material)**	0.8 – 3.0 mm (0.031 – 0.118 inch)	
Tube material	High-alloy steels (special steel material no. 1.40... – 1.45... as per DIN 17 455 and DIN 17 456), no-alloy and low-alloy steels, aluminum, casting materials, non-iron metals, PVDF plastic. Others upon request.	

\* MRA HP = Metal Tube Cutter for high-purity applications. Only applicable with the HP multi-roller cutting chain (Code 790 008 014).

\*\* for high-alloy steels, the max. wall thickness which can be processed is 2.0 – 2.5 mm (0.08 – 0.09 inch).

The technical data are not binding. They are not warranted characteristics and are subject to change. Please consult our general conditions of supply.

Info-Hotline: +49 (0) 77 31 792-787 up to 789